

European Energy Market 3

Main market rules

**Studia niestacjonarne II stopnia
Rok akademicki 2012/2013**

Władysław Mielczarski

Instytut Elektroenergetyki, Politechnika Łódzka

www.i15.p.lodz.pl/~mielczarski/

Lp	List of lectures
1	European Energy Markets
2	Polish Power System
3	Main Market Rules - Balancing
4	Electricity Trade - Power Exchange
5	Customers - TPA
6	Subsidized Markets
7	Cost of Electricity
8	Energy Mix
9	EU Emission Trade System
10	Cross border trading

Basic assumptions

- **Electrical energy is a product and it can be produced and traded in competitive markets.**
- **Electricity transport is the service provided by network operators.**
- **Electric network operators both transmission and distribution are monopolies and have to be regulated by approval of tariffs by Energy Regulatory Authority (URE).**

Unbundling – rozdział działalności wolnorynkowej od regulowanej

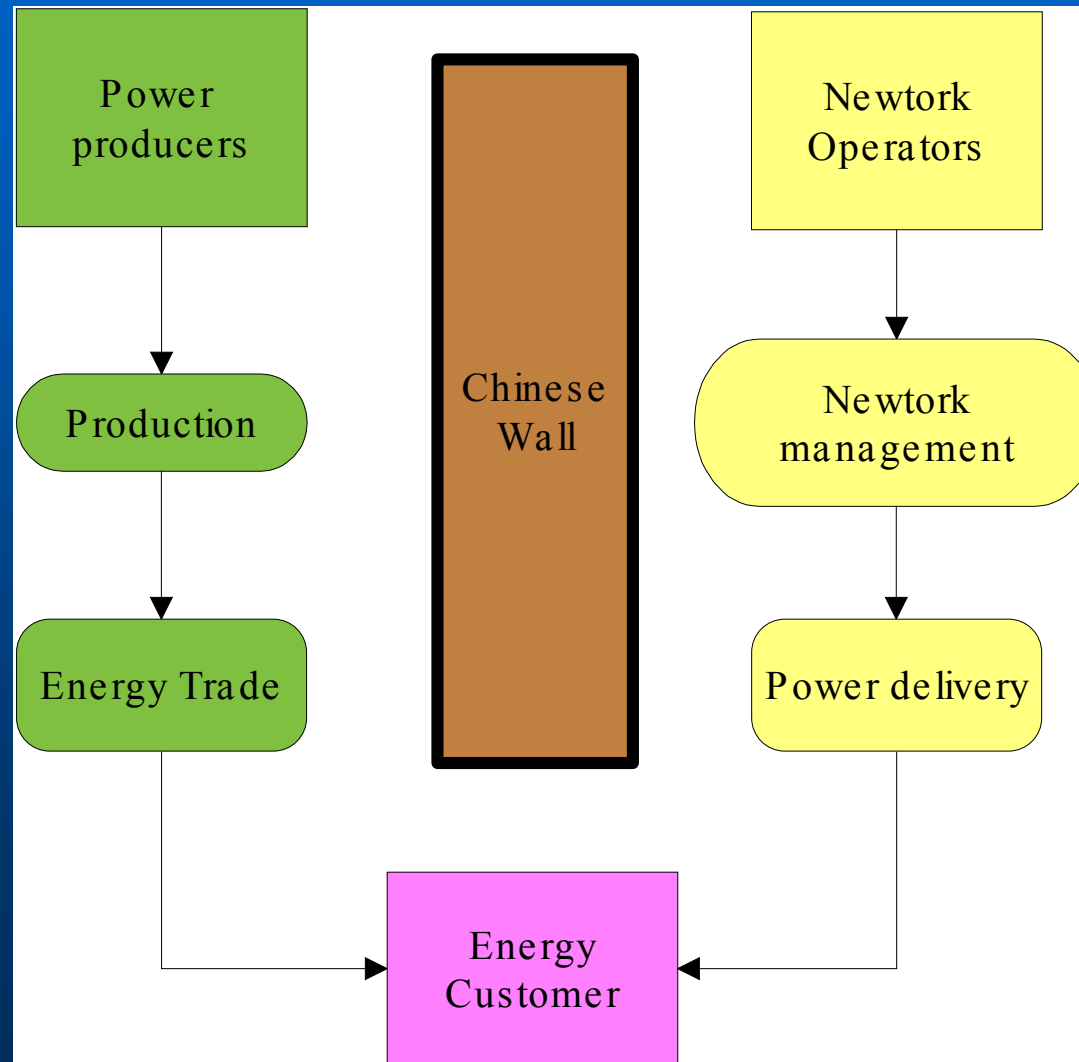

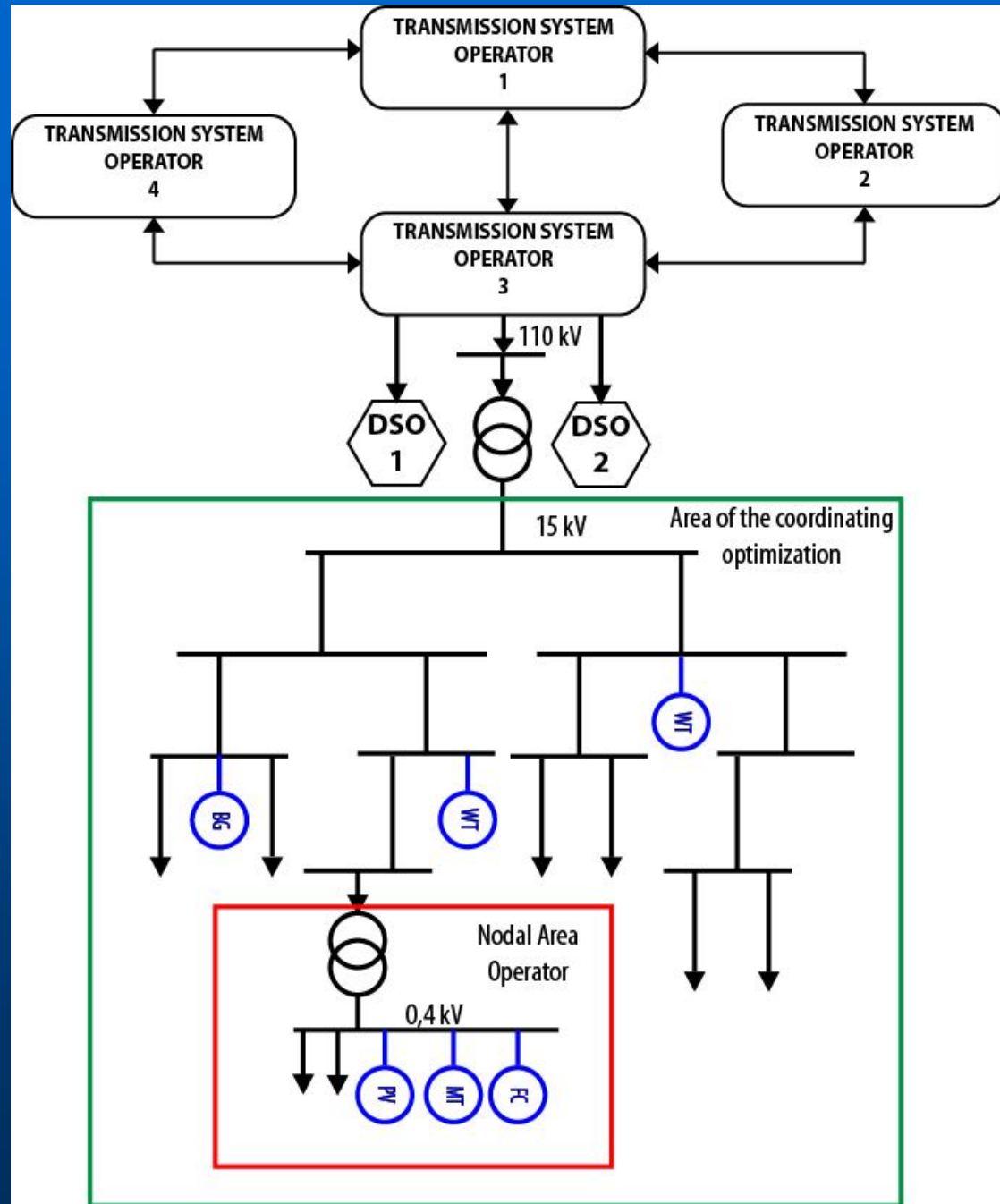

Network hierarchical systems

**DSO =
Distribution
System
Operator**

Trade of electrical energy

- Electric energy cannot be stored
- Production (supply) and demand must be balanced in every minute
- Energy is traded in one hour intervals
- Customer can purchase electricity from any trader (TPA)
- **Amount of energy used differs from the energy purchased**
- Energy trade is virtual and it does not involve the energy flow

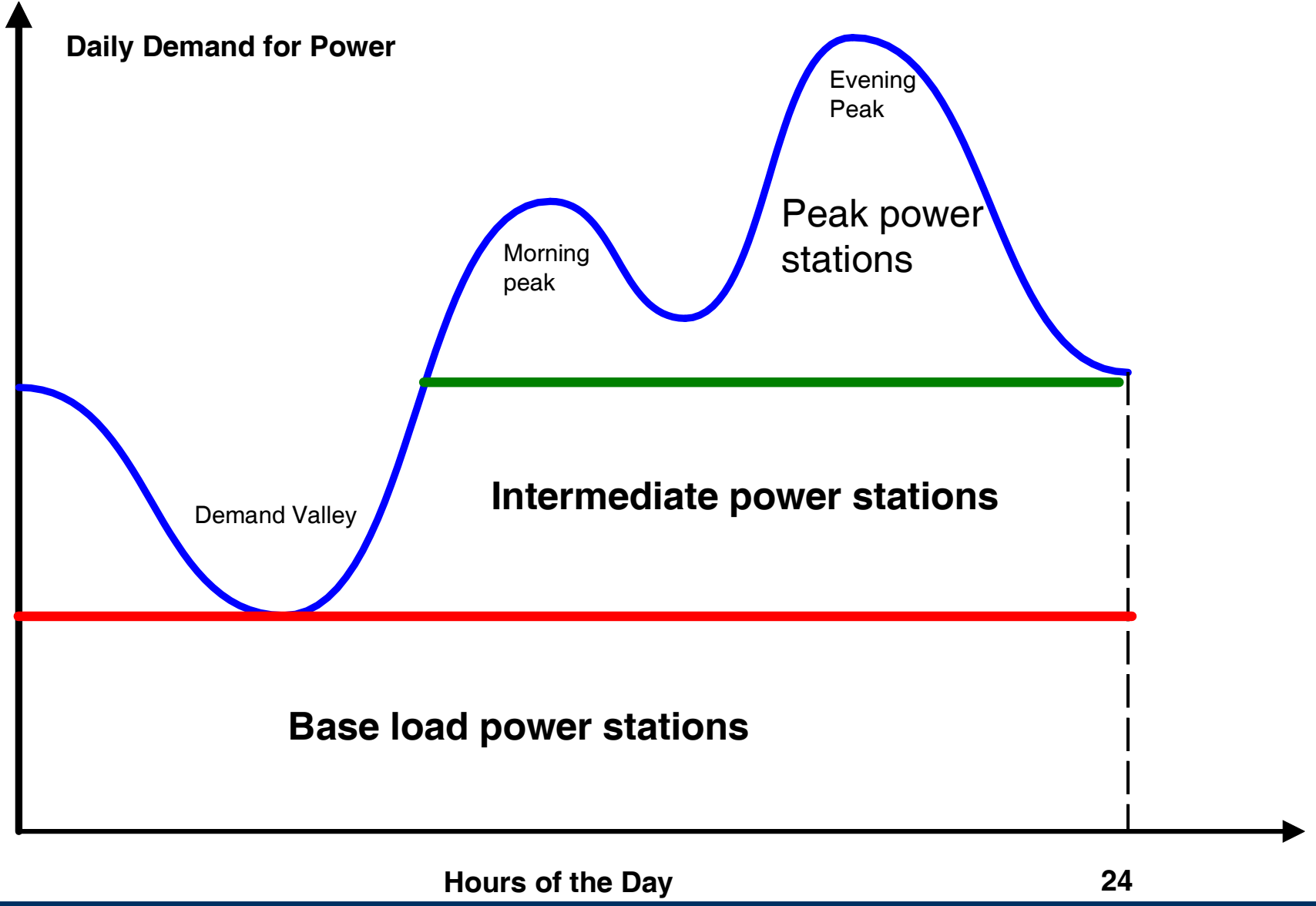

Electrical market operates in one hour intervals

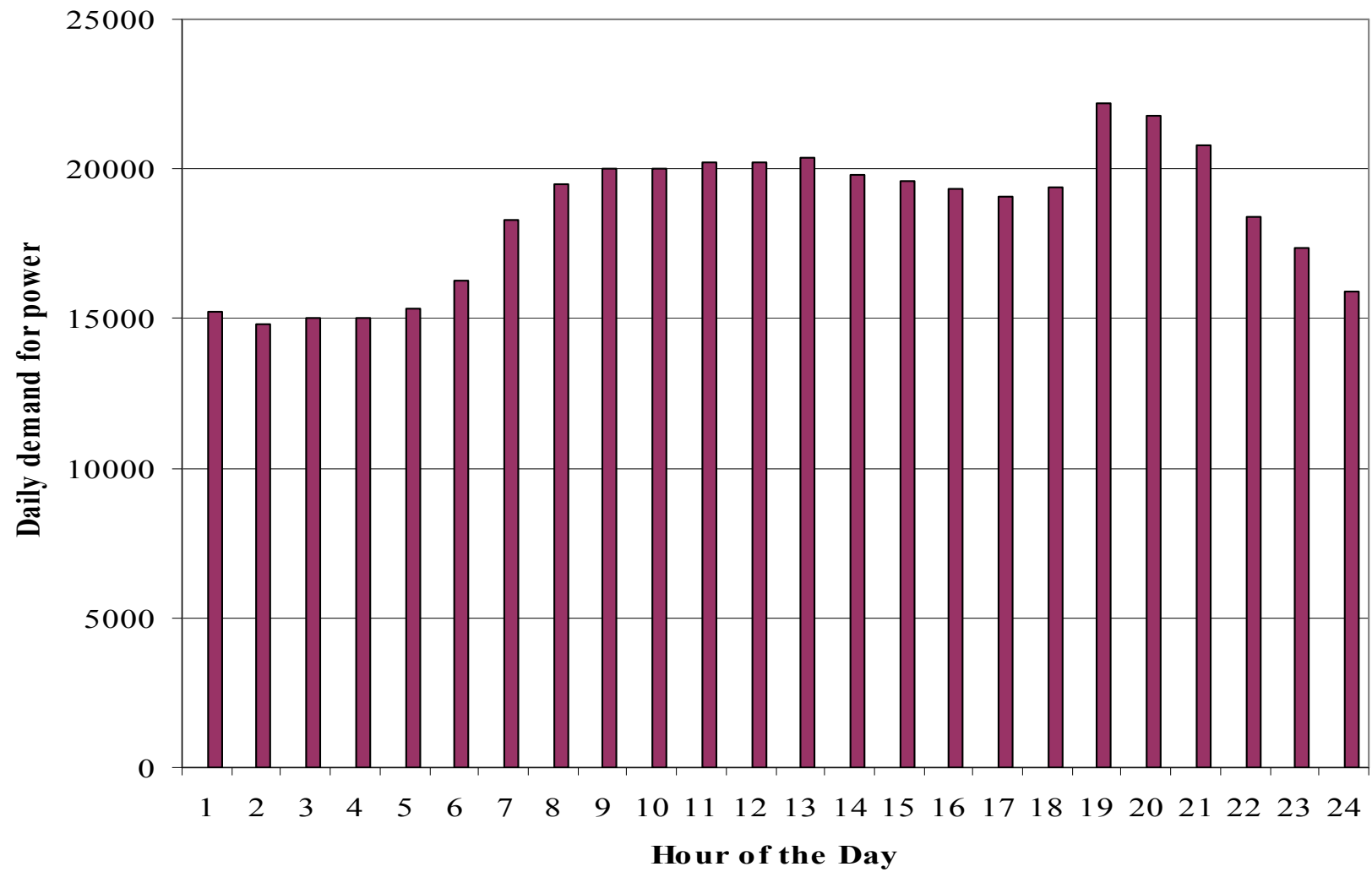

Electricity prices in PLN/MWh Power Exchange - Day Ahead Market

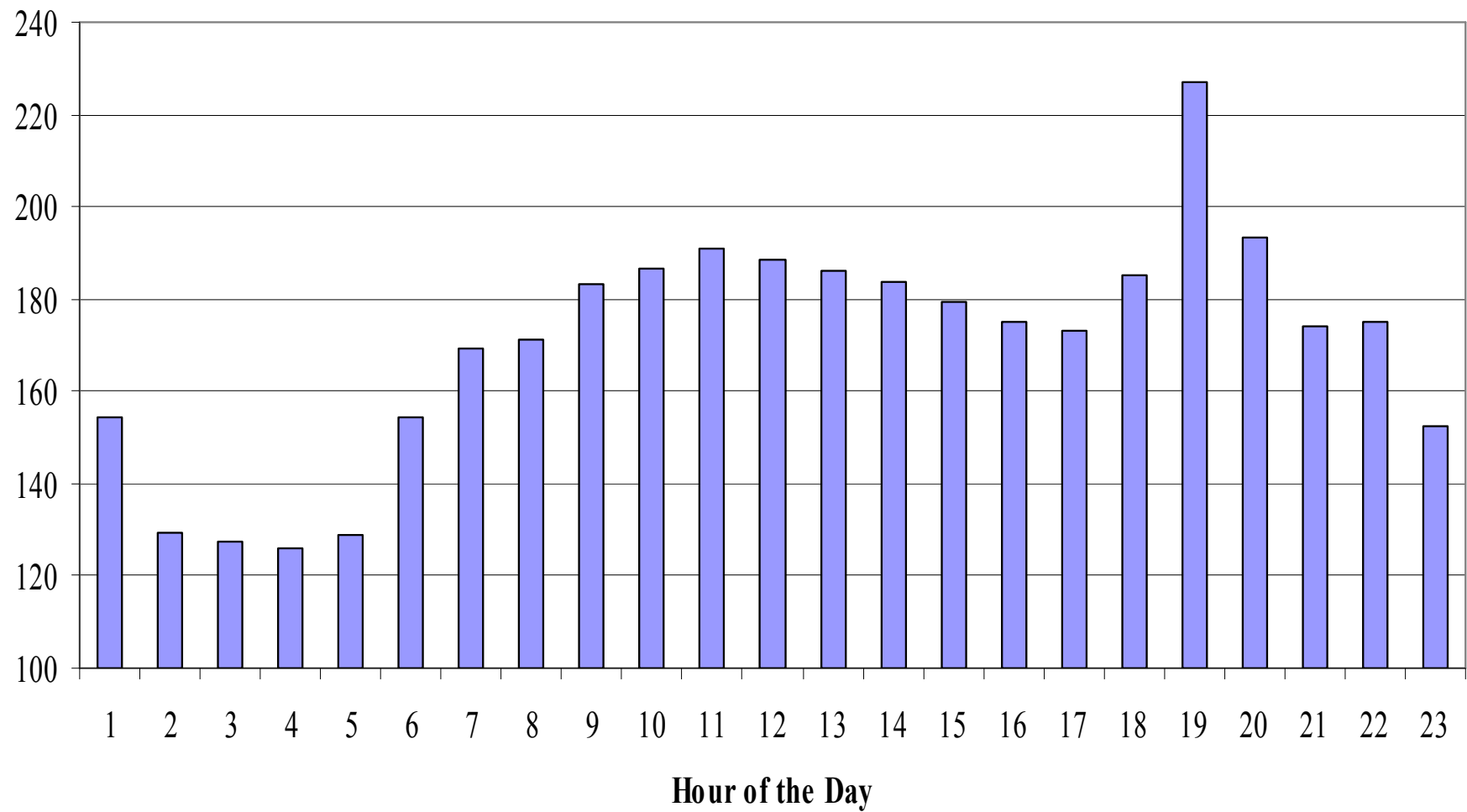

Day Ahead Market Schedule

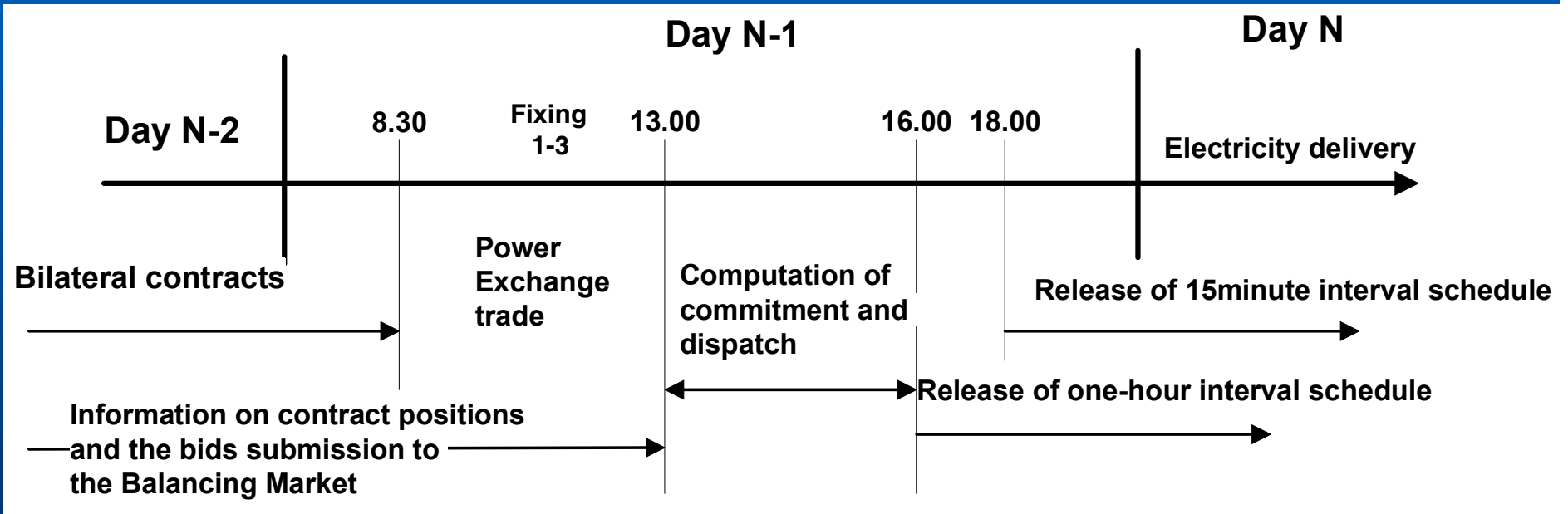

Balancing Market

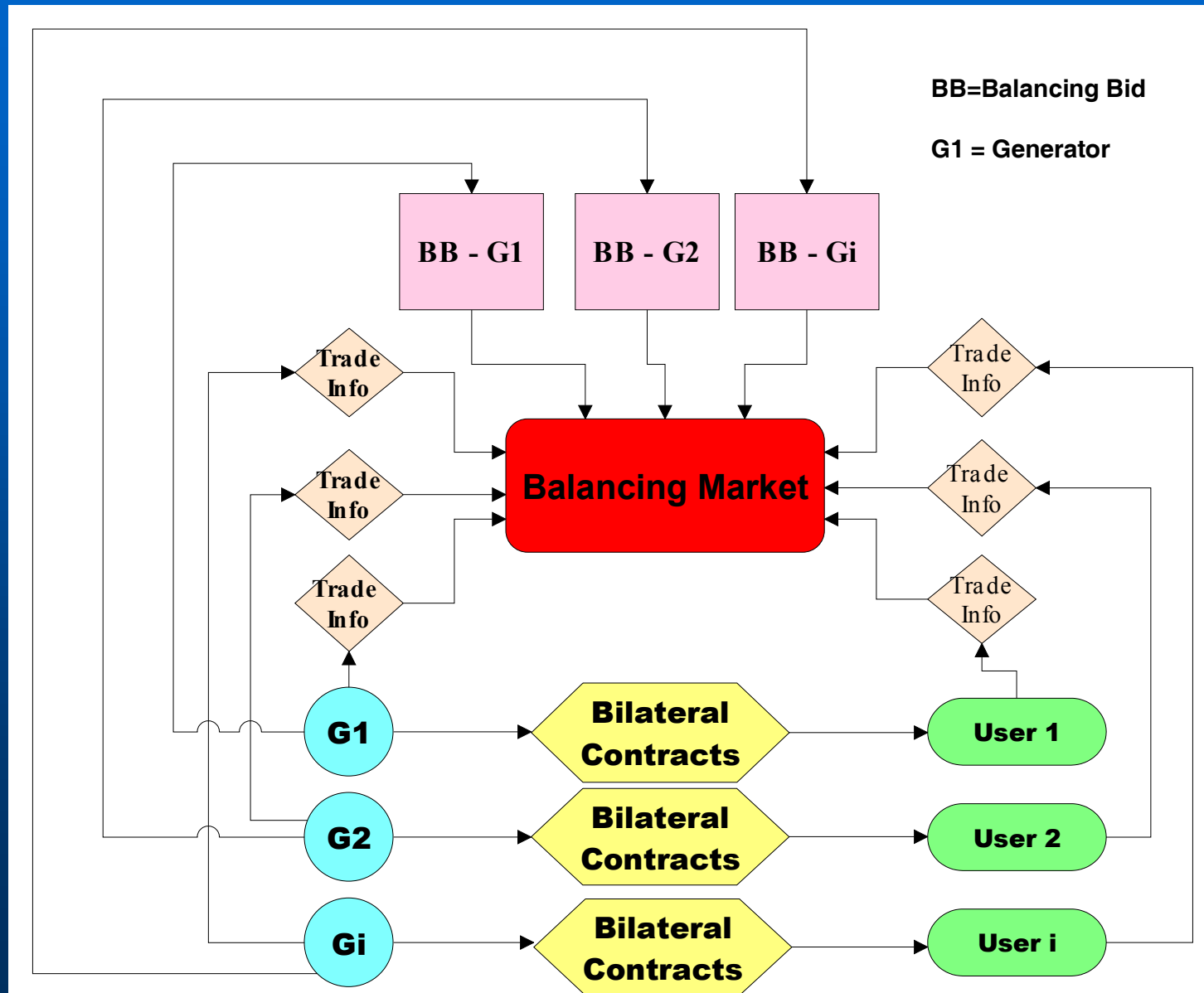

Information on Electricity Trade

G1	User 1	User 2	User 3	Total
	100	90	50	240
G2	User 1	User 2	User 3	Total
	50	80	20	150
G3	User 1	User 2	User 3	Total
	30	70	20	120
			G1+G2+G3	510
User 1	G1	G2	G3	Total
	100	50	30	180
User 2	G1	G2	G3	Total
	90	80	70	240
User 3	G1	G2	G3	Total
	50	20	20	90
	Use 1 + User 2 + User 3			510

Balance of generation and consumption

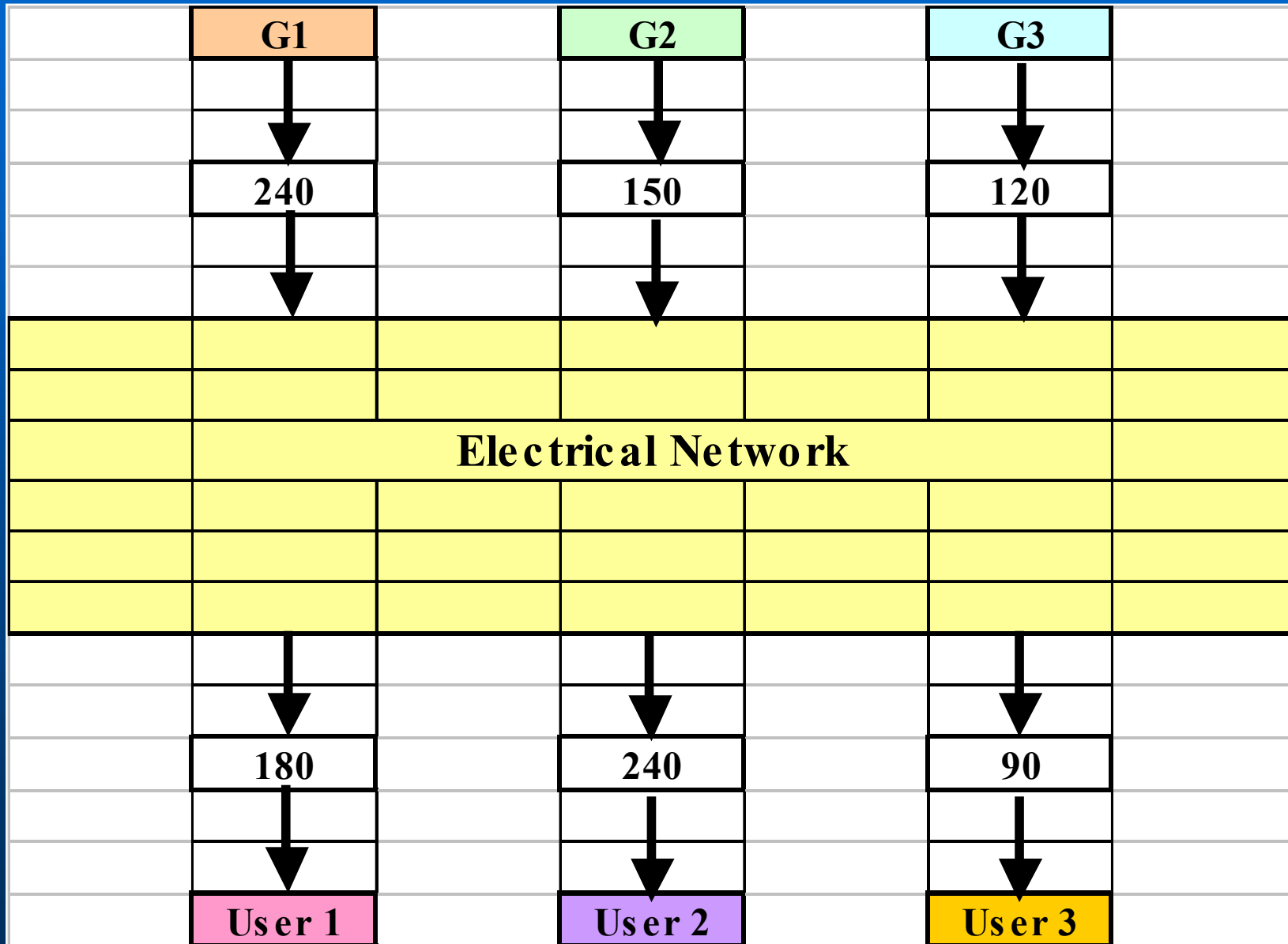

Balancing bids for every hour

G1												
Band	1	2	3	4	5	6	7	8	9	10	Trade	Total
Price - zł/MWh	70	75	80	180	182	185	187	189	195	200		
Gross - MWh	200	20	20	30	20	15	10	10	5	10	240	340
Net - MWh	184	18	18	28	18	14	9	9	5	9		
G2												
Band	1	2	3	4	5	6	7	8	9	10	Trade	Total
Price - zł/MWh	70	75	80	180	182	185	187	189	195	200		
Gross - MWh	120	20	10	20	20	15	10	10	5	10	150	240
Net - MWh	110	18	9	18	18	14	9	9	5	9		
G3												
Band	1	2	3	4	5	6	7	8	9	10	Trade	Total
Price - zł/MWh	70	75	80	180	182	185	187	189	195	200		
Gross - MWh	100	10	10	10	10	5	5	5	3	2	120	160
Net - MWh	92	9	9	9	9	5	5	5	3	2		

Balancing bids in merit order

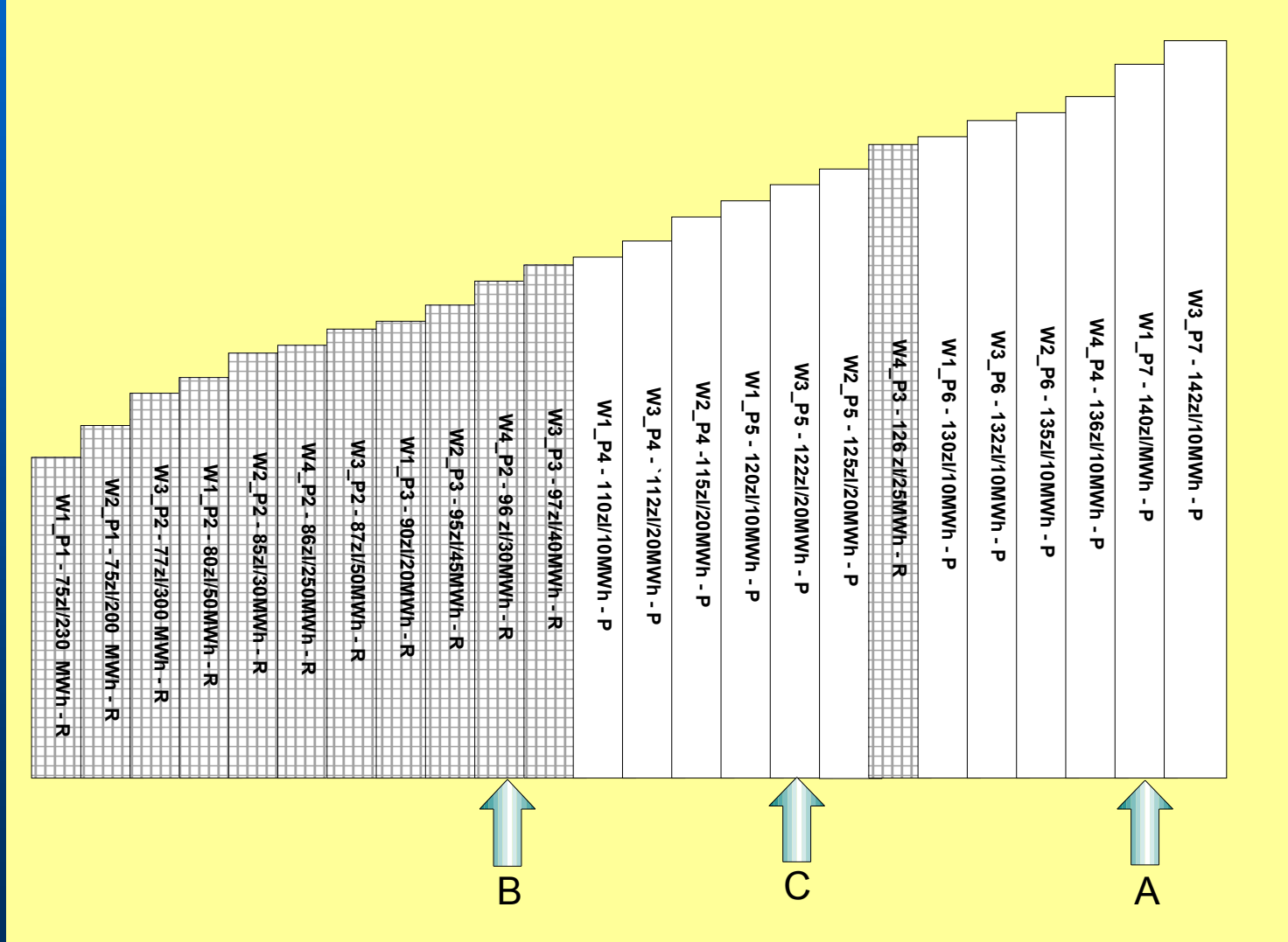

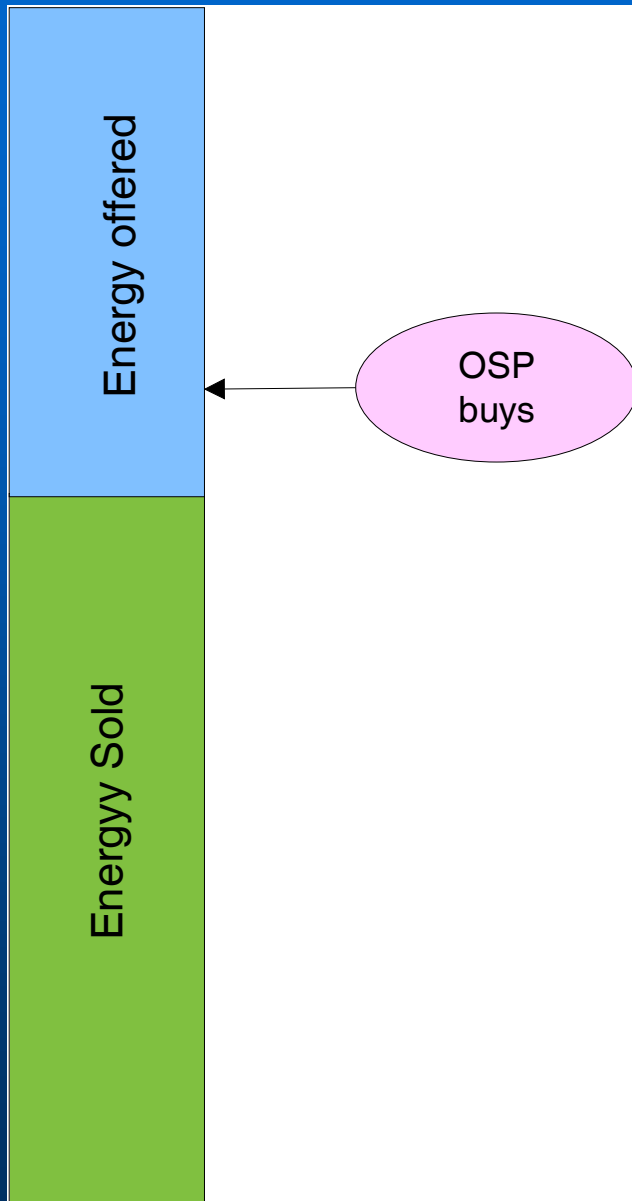

If TSO needs more energy, TSO buys it from bands of the balancing bids and pays generators

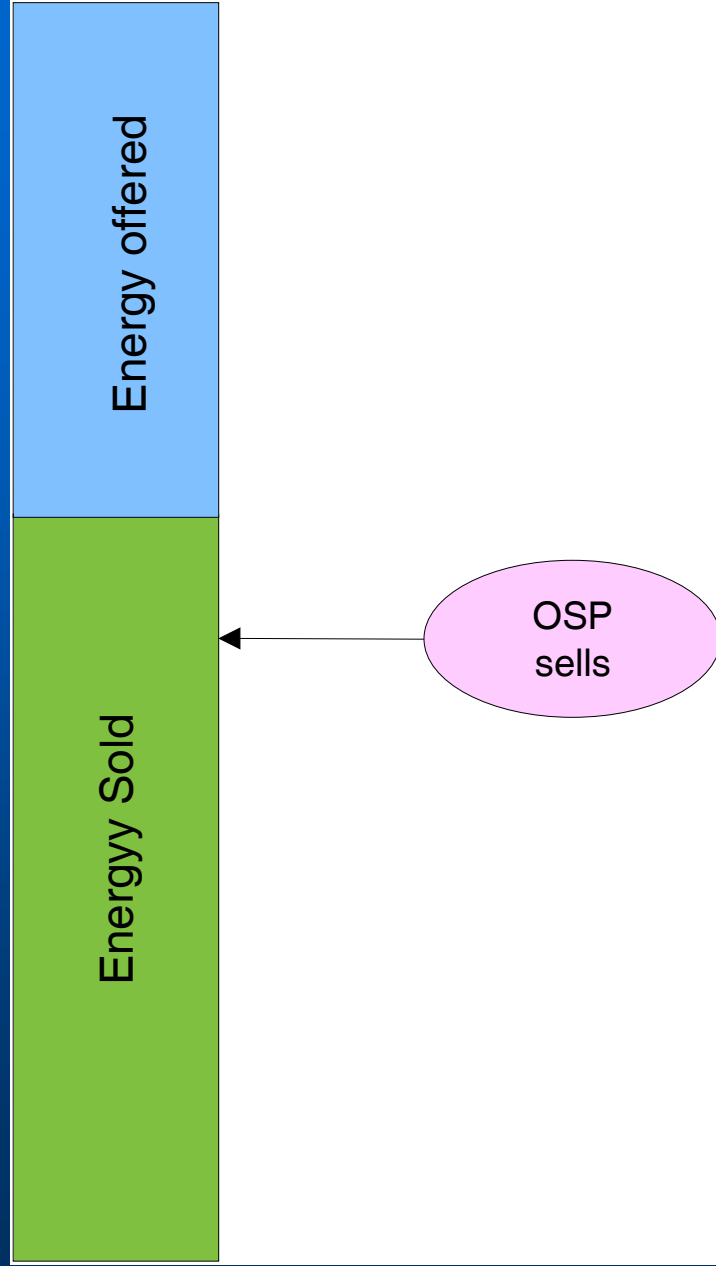

If TSO has too much energy, TSO sells it to generators using prices from balancing bids

Payments when demand is larger than trade

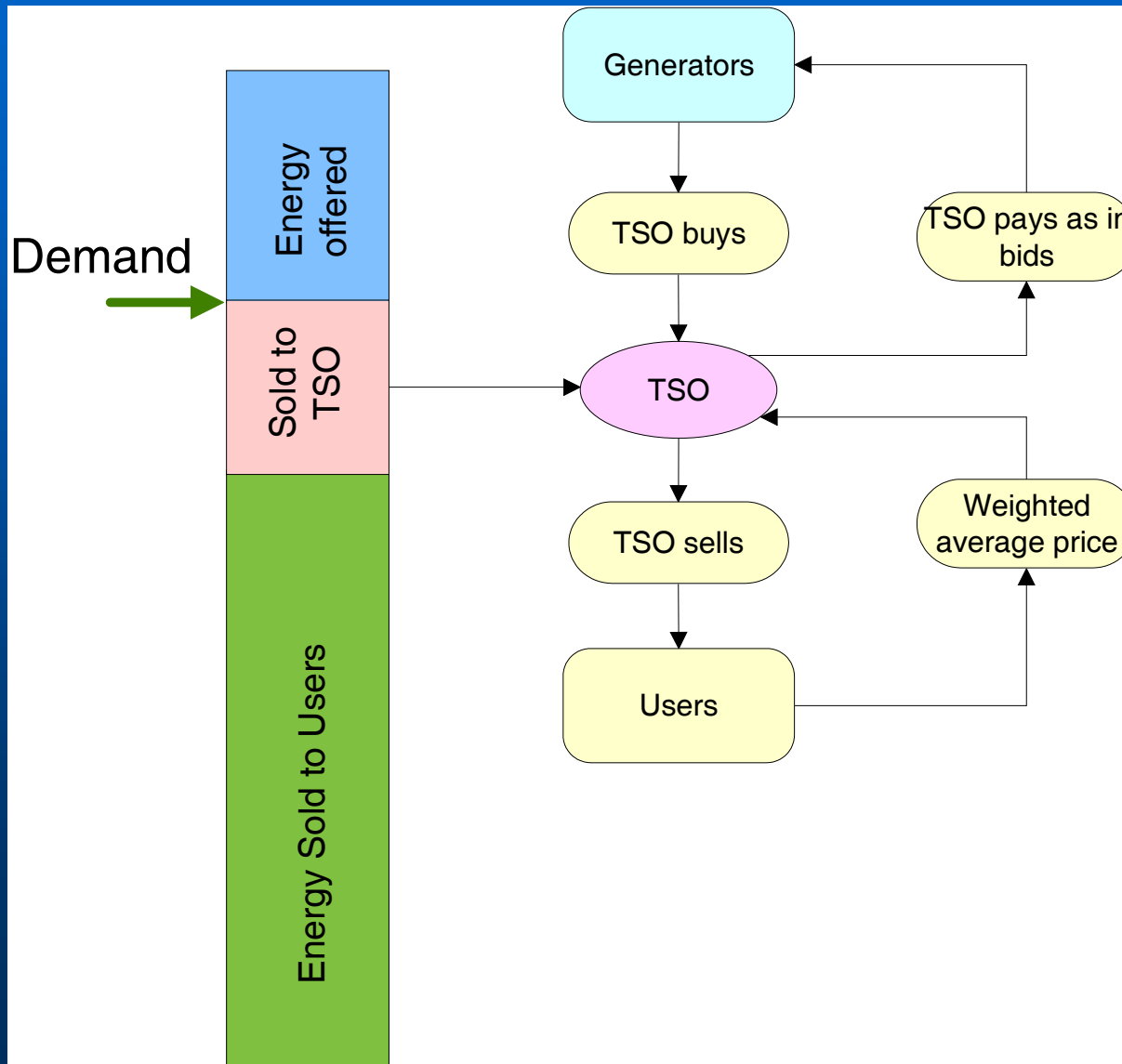

Payments when demand is smaller than trade

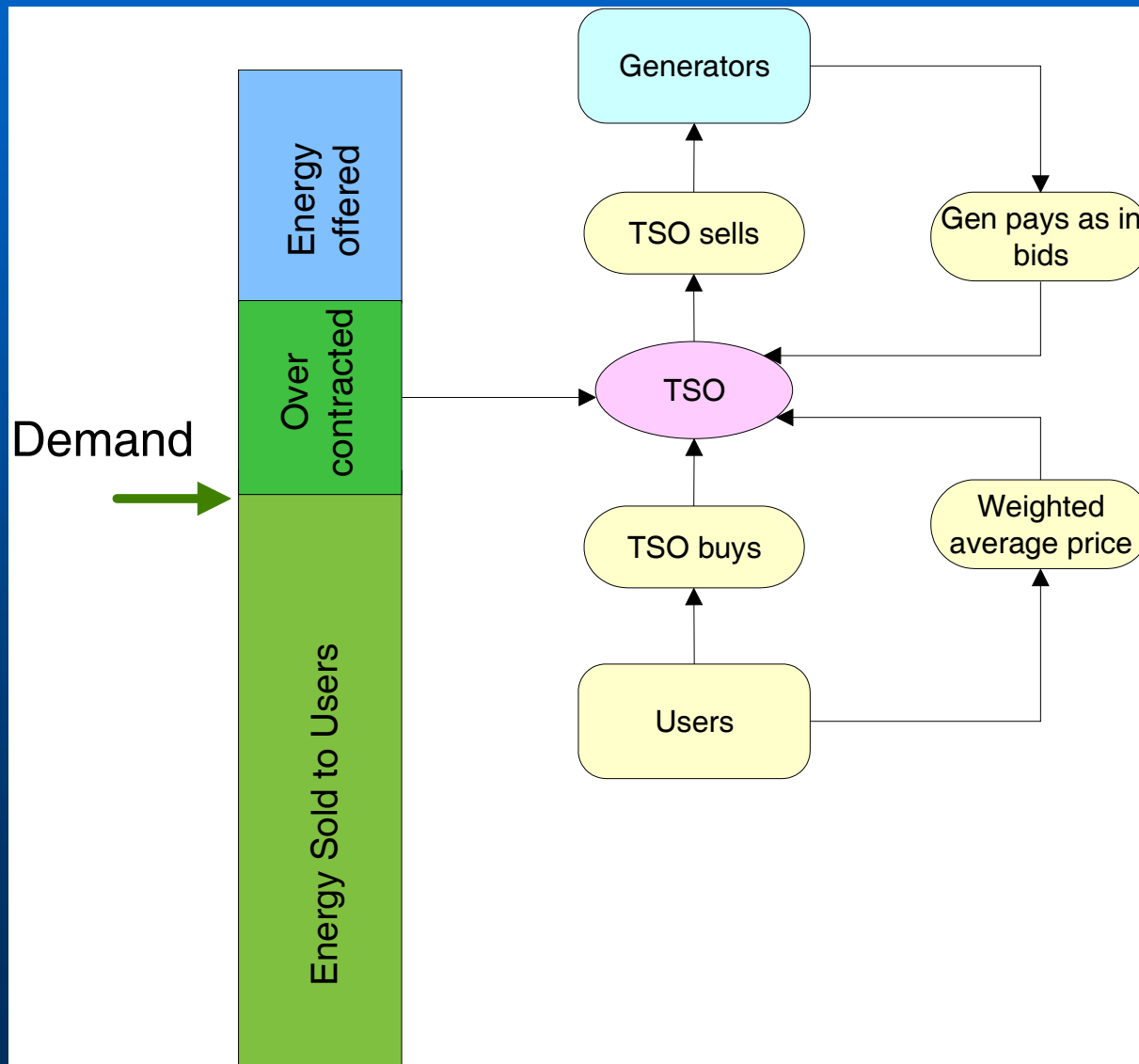

Payments in Balancing Market

